



ELECTRONICS

APPROVAL

TO : DELL/QUANTA

DATE : April 10, 2001

**SAMSUNG TFT-LCD**  
**MODEL NO. : LTN141X8-L02**

NOTE :

Any Modification of Spec is not allowed without SEC' permission

APPROVED BY : B. W. Lee

PREPARED BY : Application Engineering Team

**SAMSUNG ELECTRONICS CO., LTD.**



## CONTENTS

|   |              |
|---|--------------|
| Record Of Revision  | ----- ( 3 )  |
| General Description   | ----- ( 4 )  |
| 1. Absolute Maximum Ratings   | ----- ( 5 )  |
| 1.1 Absolute Ratings of Environment                                   |              |
| 1.2 Electrical Absolute Maximum Ratings                               |              |
| 2. Optical Characteristics  | ----- ( 7 )  |
| 3. Electrical Characteristics   | ----- ( 10 ) |
| 3.1 TFT LCD Module  |              |
| 3.2 Back Light Unit   |              |
| 3.3 Inverter  |              |
| 4. Block Diagram  | ----- ( 14 ) |
| 4.1 TFT LCD Module  |              |
| 4.2 Back Light Unit   |              |
| 4.3 Inverter  |              |
| 5. Input Terminal Pin Assignment                                      | ----- ( 16 ) |
| 5.1 Input Signal & Power  |              |
| 5.2 LVDS Interface:Transmitter  |              |
| 5.3 Back Light Unit   |              |
| 5.4 Timing Diagrams of LVDS for Transmission                          |              |
| 5.5 Inverter signals & power  |              |
| 5.6 Input Signals, Basic Display Colors and Gray Scale of Each Color. |              |
| 5.7 Pixel Format  |              |
| 6. Interface Timing   | ----- ( 23 ) |
| 6.1 Timing Parameters(DE MODE)  |              |
| 6.2 Timing Diagrams of interface Signal (DE MODE)                     |              |
| 6.3 Power ON/OFF Sequence   |              |
| 7. Outline Dimension  | ----- ( 25 ) |
| 8. Packing  | ----- ( 26 ) |
| 9. Markings & Others  | ----- ( 27 ) |
| 10. General Precaution  | ----- ( 29 ) |

## REVISION HISTORY

APPROVAL

| Date        | Rev.No. | Page | Summary   |
|-------------|---------|------|---|
| Jur.27,2000 | P00     | ALL  | LTN141X8-L02 model was First issued.  |
| Dec.13,2000 | P01     | 5    | Mechanical Information<br>-Module size tolerance : $\pm 0.5 \rightarrow \pm 0.3$<br>-Weight : (550g) $\rightarrow$ 520g   |
|             |         | 7    | Update color chromaticity(CIE)  |
|             |         | 13   | Add Inverter electrical characteristics   |
|             |         | 15   | Add Inverter block diagram  |
|             |         | 19   | Add Inverter input pin definition   |
| Aug.28,2000 | P02     | 5    | Add measurement condition of outline dimension<br>Add the user hole torque  |
|             |         | 7    | 13 points white variation : 2.0 $\rightarrow$ 1.75  |
| Sep.B,2000  | A00     | -    | RTS & MP start  |
| Sep.28,2000 | A01     | -    | Change the epoxy material around inverter connector<br>: Threebond $\rightarrow$ Eccobond   |
| Oct.28,2000 | A02     | -    | Inverter Bracket thickness : 0.3t $\rightarrow$ 0.2t<br>Gate PCB cover : PET $\rightarrow$ Al type<br>Multiplication of B/L Unit : Yuka, Wooyoung $\rightarrow$ Yuka, Wooyoung, <a href="#">Taesan</a>                    |
| Nov.28,2000 | A03     | -    | Change the production line : Line 3 $\rightarrow$ Line 3 & <a href="#">Line 4</a>   |
| Feb.08,2001 | A04     | -    | Multiplication of S/D IC : SEC LDI $\rightarrow$ SEC LDI, <a href="#">Hitachi</a><br>Change the V/R : RH02AXC $\rightarrow$ RH02B1C<br>Multiplication of SEC LDI S/D IC Film : COF $\rightarrow$ COF, <a href="#">TCP</a> |
| Mar.15,2001 | A05     | -    | Inverter input connector : Epoxy type $\rightarrow$ Long term connector<br>(4 through hole type)  |
| Apr.06,2001 | A06     | -    | Multiplication of inverter : Ambit $\rightarrow$ Ambit, Sumida  |
|             |         | 20   | Add the inverter part name and revision number  |
|             |         | 27   | Add the PPID label and change revision code   |

## GENERAL DESCRIPTION

### DESCRIPTION

LTN141X8-L02 is a color active matrix TFT (Thin Film Transistor) liquid crystal display (LCD) that uses amorphous silicon TFT as a switching devices. This model is composed of a TFT LCD panel, a driver circuit, a back-light system, inverter, brackets, FPC. The resolution of a 14.1 " contains 1024 x 768 pixels and can display up to 262,144colors. 6 o'clock direction is the optimum viewing angle.

### FEATURES

- Thin and light weight
- High contrast ratio, high aperture structure
- XGA (1024x768 pixels) resolution
- Low power consumption
- Single CCFL
- DE(Data enable) only mode
- 3.3V LVDS Interface

### APPLICATIONS

- Notebook PC and desktop monitors
- Display terminals for AV application products
- Monitors for Industrial machine
- If the usage of this product is not for PC application, but for others, please contact SEC

### GENERAL INFORMATION

| ITEM              | SPECIFICATION                             | UNIT  | NOTE |
|-------------------|---|-------|------|
| Display area      | 285.696(H) x 214.272(V) (14.1" diagonal ) | mm    |      |
| Driver element    | a-Si TFT active matrix                    |       |      |
| Display colors    | 262,144                                   |       |      |
| Number of pixel   | 1024 x 768                                | pixel |      |
| Pixel arrangement | RGB vertical stripe                       |       |      |
| Pixel pitch       | 0.279(H) x 0.279(V) (TYP.)                | mm    |      |
| Display Mode      | Normally white                            |       |      |
| Surface treatment | HAZE 25, HARD-COATING 3H                  |       |      |

**Mechanical Information**

| ITEM        |                | MIN.  | TYP.  | MAX.  | NOTE                       |
|-------------|----------------|-------|-------|-------|----------------------------|
| Module size | Horizontal (H) | 298.2 | 298.5 | 298.8 | LCD panel only             |
|             | Vertical (V)   | 226.2 | 226.5 | 226.8 |                            |
|             | Depth (D)      | -     | -     | 6.4   | Inverter assembly (1), (2) |
| Weight      |                | -     | 500   | 520   | LCD panel only             |
|             |                | -     | 510   | 535   | Inverter assembly          |

Note (1) Measurement condition of outline dimension

- . Equipment : Vernier Calipers
- . Push Force : 500g · f (minimum)

(2) User Hole Torque : 2.8 kg·f·cm, 5 times

## 1. ABSOLUTE MAXIMUM RATINGS

### 1.1 ENVIRONMENTAL ABSOLUTE RATINGS

| ITEM  | SYMBOL           | MIN. | MAX. | UNIT | NOTE    |
|---|------------------|------|------|------|---------|
| Storage temperature                                     | T <sub>STG</sub> | -25  | 60   | %°C  | (1)     |
| Operating temperature<br>(Temperature of glass surface) | T <sub>OPR</sub> | 0    | 50   | %°C  | (1)     |
| Shock ( non-operating )                                 | Snop             | -    | 220  | G    | (2),(4) |
| Vibration (non-operating)                               | Vnop             | -    | 1.5  | G    | (3),(4) |

Note (1) Temperature and relative humidity range are shown in the figure below.

95 % RH Max. ( 40°C ≥ Ta)

Maximum wet - bulb temperature at 39°C or less. (Ta > 40°C) No condensation.

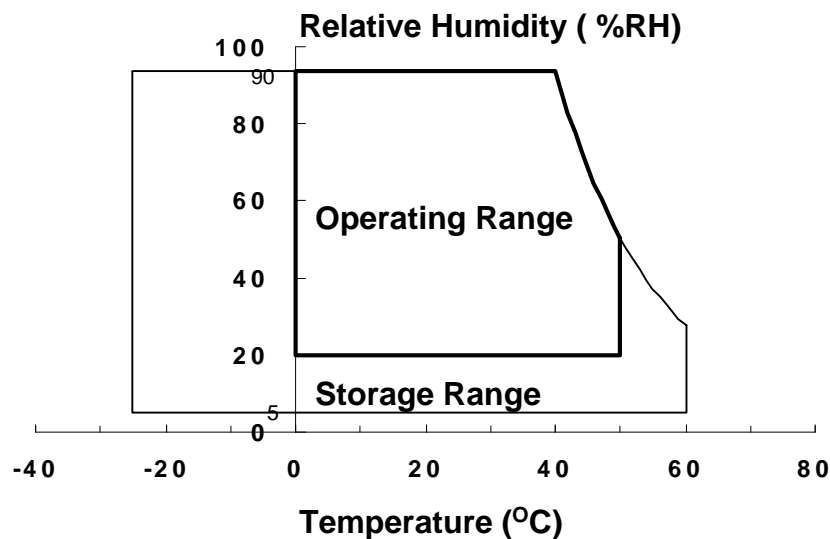

(2) 220G, 2ms, Half sine wave, one time for ±X, ±Y, ±Z axis

(3) 10 ~ 300 ~ 10 Hz, Sweep rate 10min, 30min for X, Y,Z axis

(4) At testing Vibration and Shock, the fixture in holding the Module to be tested have to be hard and rigid enough so that the Module would not be twisted or bent by the fixture.

## 1.2 ELECTRICAL ABSOLUTE RATINGS

## (1) TFT LCD MODULE

VDD =3.3, Vss=GND= 0V

| ITEM                 | SYMBOL          | MIN.     | MAX.    | UNIT | NOTE |
|----------------------|-----------------|----------|---------|------|------|
| Power Supply Voltage | VDD             | Vss -0.3 | 4.0     | V    | (1)  |
| Logic Input Voltage  | V <sub>IN</sub> | Vss -0.3 | VDD+0.3 | V    | (1)  |

NOTE (1) Within Ta = 25 ± 2 °C

## (2) BACK-LIGHT UNIT

Ta = 25 ± 2 °C

| ITEM           | SYMBOL         | MIN. | MAX. | UNIT. | NOTE |
|----------------|----------------|------|------|-------|------|
| Lamp current   | I <sub>L</sub> | 3.0  | 6.5  | mArms | (1)  |
| Lamp frequency | FL             | 30   | 80   | KHz   | (1)  |

NOTE (1) Permanent damage to the device may occur if maximum values are exceeded.  
Functional operation should be restricted to the conditions described under Normal Operating Conditions.

## 2. OPTICAL CHARACTERISTICS

The following items are measured under stable conditions. The optical characteristics should be measured in a dark room or equivalent state with the methods shown in Note (5).  
 Measuring equipment : TOPCON BM-5A

\* Ta = 25 ± 2°C , VDD=3.3V, fv= 60Hz, fdCLK=65MHz, IL = 6.0 mA

| ITEM                                     |         | SYMBOL     | CONDITION   | MIN.  | TYP.  | MAX.  | UNIT    | NOTE              |                    |
|--|---------|------------|---|-------|-------|-------|---------|-------------------|--------------------|
| Contrast Ratio<br>(5 Points)             |         | CR         |   | 150   | -     | -     |         | (1), (2), (5)     |                    |
| Response<br>Time at Ta                   | Rising  | TR         | $\phi = 0,$<br>$\theta = 0$<br>Normal<br>Viewing<br>Angle | -     | 10    | 50    | msec    | (1), (3)          |                    |
|  | Falling | TF         |   | -     | 30    | 50    |         |                   |                    |
| Average Luminance<br>of White (5 Points) |         | YL,AVE     |   |       | 110   | 140   | -       | cd/m <sup>2</sup> | (1), (4)<br>at 6mA |
| Color<br>Chromaticity<br>( CIE )         | Red     | Rx         |   |       | 0.535 | 0.565 | 0.595   |                   | (1), (5)           |
|  |         | Ry         |   |       | 0.300 | 0.330 | 0.360   |                   |                    |
|  | Green   | Gx         |   |       | 0.290 | 0.320 | 0.350   |                   |                    |
|  |         | Gy         |   |       | 0.480 | 0.510 | 0.540   |                   |                    |
|  | Blue    | Bx         |   |       | 0.122 | 0.152 | 0.182   |                   |                    |
|  |         | By         |   |       | 0.113 | 0.143 | 0.173   |                   |                    |
|  | White   | Wx         |   |       | 0.283 | 0.313 | 0.343   |                   |                    |
|  |         | Wy         |   | 0.299 | 0.329 | 0.359 |         |                   |                    |
| Viewing<br>Angle                         | Hor.    | $\theta_L$ | CR( at<br>center point)<br>≥ 10                           | 40    | 45    | -     | Degrees |                   |                    |
|  |         | $\theta_R$ |   | 40    | 45    | -     |         |                   |                    |
|  | Ver.    | $\phi_H$   |   | 15    | 20    | -     |         |                   |                    |
|  |         | $\phi_L$   |   | 35    | 40    | -     |         |                   |                    |
| 13 Points<br>White Variation             |         | $\delta_L$ |   | -     | -     | 1.75  |         | (6)               |                    |

Note 1) Definition of Viewing Angle :

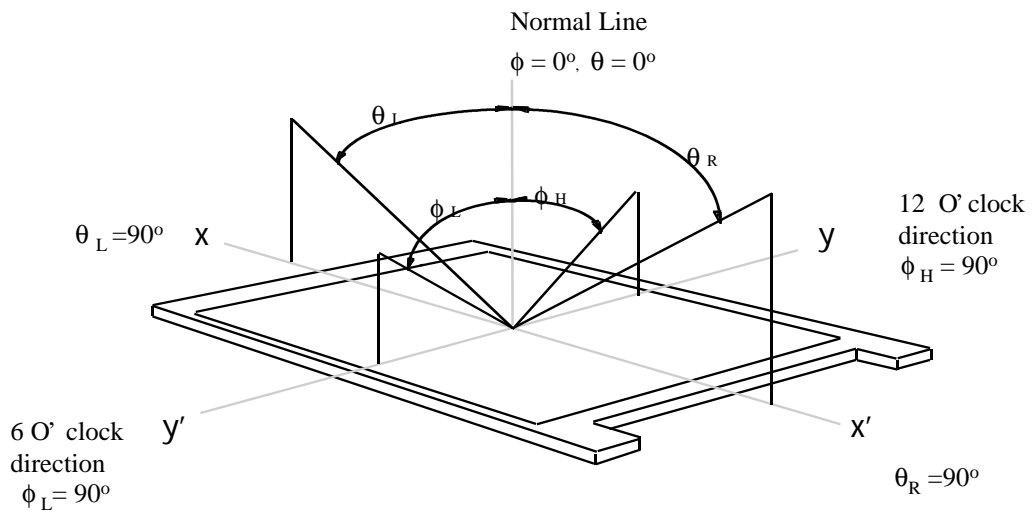

Note 2) Definition of Contrast Ratio (CR) :

$$CR = \frac{CR1 + CR2 + CR3 + CR4 + CR5}{5}$$

POINTS : (4) , (5) , (7) , (9) , (10) at FIGURE OF NOTE 6)

Note 3) Definition of Response time :

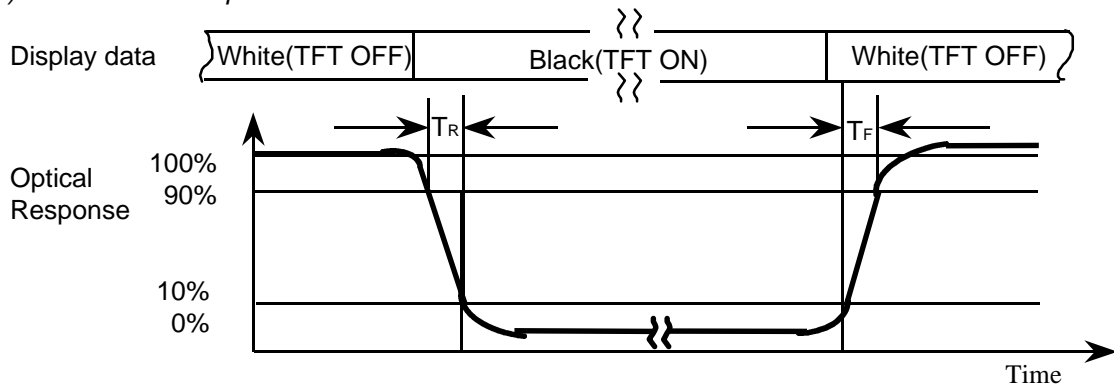

Note 4) Definition of Average Luminance of White : measure the luminance of white at 5 points.

Average Luminance of White (  $Y_{L,AVE}$  )

$$Y_{L,AVE} = \frac{Y_{L4} + Y_{L5} + Y_{L7} + Y_{L9} + Y_{L10}}{5}$$

POINTS : (4) , (5) , (7) , (9) , (10) at FIGURE OF NOTE 6)



Note 5) After stabilizing and leaving the panel alone at a given temperature for 30 minutes, the measurement should be executed. Measurement should be executed in a stable, windless, and dark room. 30 minutes after lighting the back-light. This should be measured in the center of screen.  
 Lamp current : 6.0 mA  
 Environment condition :  $T_a = 25 \pm 2 \text{ }^\circ\text{C}$

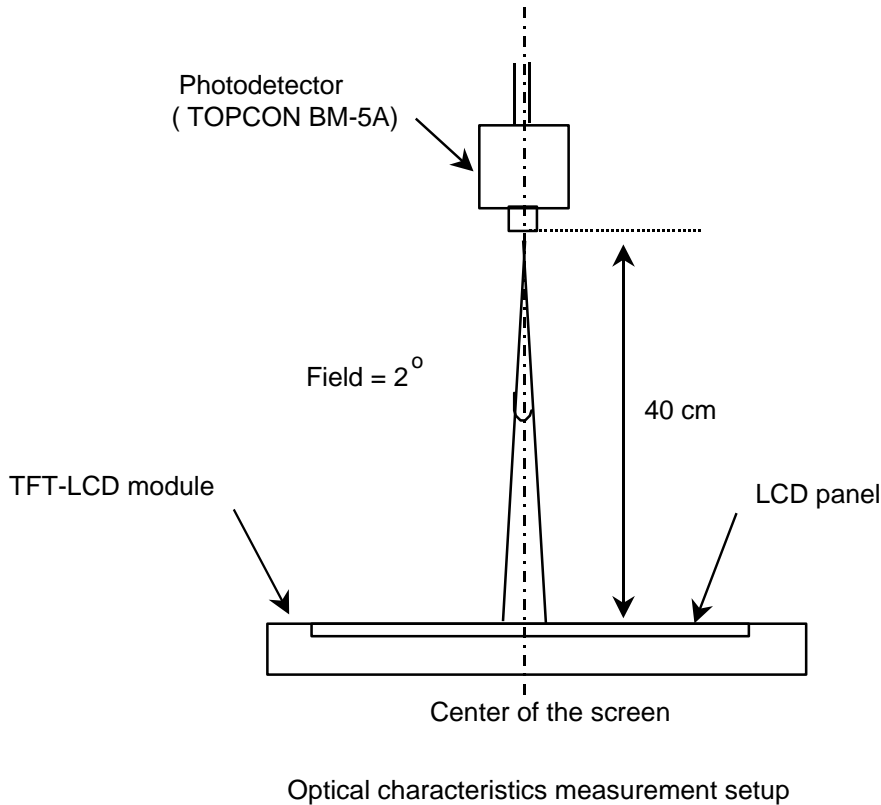

Note 6) Definition of 13 points white variation ( $d_w$ ), CR variation ( $C_{VER}$ ) [ ① ~ ⑬ ]

$$\delta L = \frac{\text{Maximum luminance of 13 points}}{\text{Minimum luminance of 13 points}} \quad \delta C_R = \frac{\text{Maximum CR of 13 points}}{\text{Minimum CR of 13 points}}$$

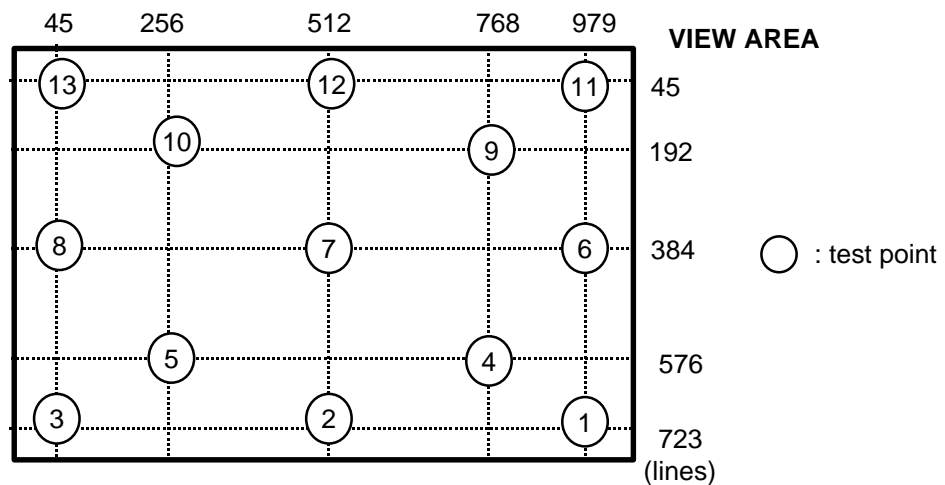

### 3. ELECTRICAL CHARACTERISTICS

APPROVAL

#### 3.1 TFT LCD MODULE

Ta = 25 ± 2%°C

| ITEM   |                 | SYMBOL            | MIN  | TYP  | MAX  | UNIT | NOTE      |
|--|-----------------|-------------------|------|------|------|------|-----------|
| Voltage of Power Supply                                |                 | V <sub>DD</sub>   | 3.0  | 3.3  | 3.6  | V    |           |
| Differential Input Voltage for LVDS Receiver Threshold | High            | V <sub>IH</sub>   | -    | -    | +100 | mV   | (1)       |
|  | Low             | V <sub>IL</sub>   | -100 | -    | -    | mV   |           |
| Vsync Frequency  |                 | f <sub>v</sub>    | -    | 60   | -    | Hz   |           |
| Hsync Frequency  |                 | f <sub>H</sub>    | -    | 48.3 | -    | KHz  |           |
| Main Frequency   |                 | f <sub>DCLK</sub> | -    | 65   | -    | MHz  |           |
| Rush Current   |                 | I <sub>RUSH</sub> | -    | -    | 1.5  | A    | (4)       |
| Current of Power Supply                                | White           | I <sub>DD</sub>   | -    | 250  | -    | mA   | (2),(3)*a |
|  | Mosaic          |                   | -    | 300  | -    | mA   | (2),(3)*b |
|  | Maximum current |                   | -    | 400  | 500  | mA   | (2),(3)*c |

- Note (1) Condition : V<sub>CM</sub>=+1.2V(Common mode Voltage)  
 (2) f<sub>v</sub>=60Hz, f<sub>DCLK</sub> =65MHZ, V<sub>dd</sub> = 3.3V , DC Current.  
 (3) Power dissipation check pattern

\*a) White Pattern

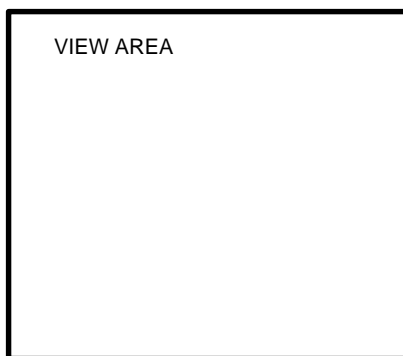

\*b)Mosaic Pattern

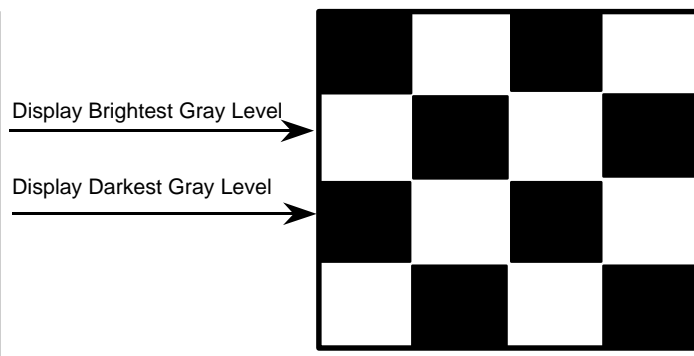

\*c) Maximum current pattern (0,7gray dot inversion)

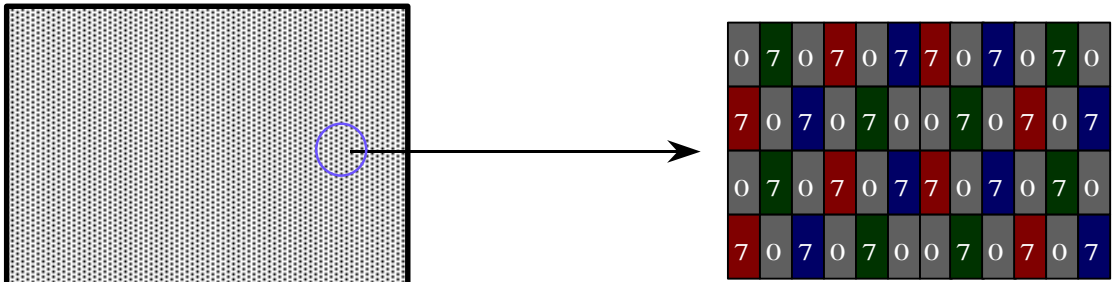

# Dark : 0, Bright : 7Gray

(4) Rush current measurement condition

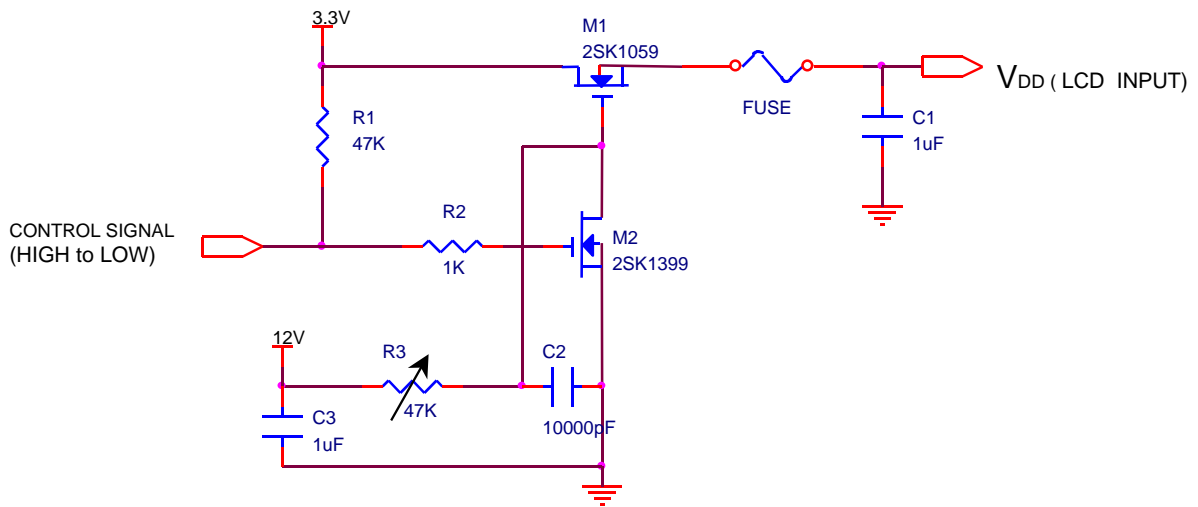

V<sub>DD</sub> rising time is 470us

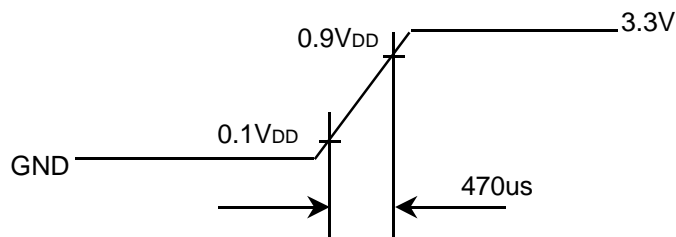

### 3.2 BACK-LIGHT UNIT

The backlight system is an edge - lighting type with a single CCFT ( Cold Cathode Fluorescent Tube ).  
The characteristics of a single lamp are shown in the following tables.

INVERTER : AMBIT/SUMIDA

$T_a = 25 \pm 2^\circ\text{C}$

| ITEM                | SYMB  | MIN    | TYP | MAX  | UNIT  | NOTE                      |
|---------------------|-------|--------|-----|------|-------|---------------------------|
| Lamp Current        | $I_L$ | 3.0    | 5.0 | 6.0  | mArms | (1)                       |
| Lamp Voltage        | $V_L$ | -      | 660 | -    | Vrms  | $I_L=5.0\text{mA}$        |
| Frequency           | $f_L$ | 50     | -   | 65   | KHz   | (2)                       |
| Power Consumption   | $P_L$ | -      | 3.3 | -    | W     | (3)<br>$I_L=6.0\text{mA}$ |
| Operating Life Time | Hr    | 10,000 | -   | -    | Hour  | (4)                       |
| Startup Voltage     | $V_s$ | -      | -   | 1100 | Vrms  | $25^\circ\text{C}$        |
|                     |       | -      | -   | 1200 | Vrms  | $0^\circ\text{C}$         |
| Lamp Startup Time   | $V_s$ | -      | -   | 1    | sec   | (5)                       |

Note) **The waveform of the inverter output voltage must be area symmetric and the design of the inverter must have specifications for the modularized lamp.**

The performance of the back-light, for example life time or brightness, is much influenced by the characteristics of the DC-AC inverter for the lamp. So all the parameters of an inverter should be carefully designed so as not to produce too much leakage current from high-voltage output of the inverter. When you design or order the inverter, please make sure that a poor lighting caused by the mismatch of the back-light and the inverter(miss lighting, flicker, etc.) never occur. When you confirm it, the module should be operated in the same condition as it is installed in your instrument.

Note (1) Lamp current is measured with a high frequency current meter as shown below.

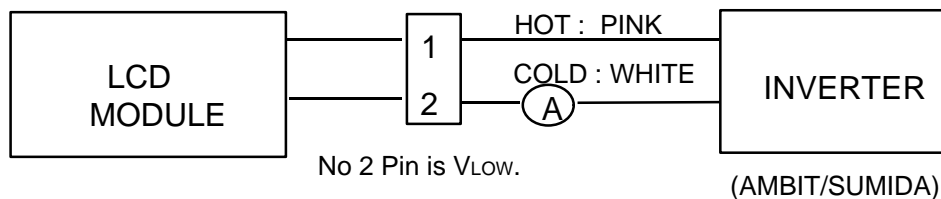

(2) Lamp frequency may produce interference with horizontal synchronous frequency and this may cause line flow on the display. Therefore lamp frequency should be detached from the horizontal synchronous frequency and its harmonics as far as possible in order to avoid interference.

(3) refer to  $I_L \times V_L$  to calculate.

(4) Life time (Hr) of a lamp can be defined as the time in which it continues to operate under the condition  $T_a = 25 \pm 2^\circ\text{C}$  and  $I_L = 6.0 \text{ mArms}$  until one of the following event occurs.

1. When the brightness becomes 50% or lower than it's original.
2. When the Effective ignition length becomes 80% or lower than it's original value.  
(Effective ignition length is defined as an area that has less than 70% brightness compared to the brightness in the center point.)

(5) The voltage above this value should be applied to the lamp for more than 1 second to startup. Otherwise the lamp may not be turned on.

## 3.3 INVERTER

Inverter Manufacturer : AMBIT, SUMIDA

Ta = 25 ± 2°C

| ITEM                    |            | MIN                    | TYP  | MAX                    | UNIT  | NOTE  |
|-------------------------|------------|------------------------|------|------------------------|-------|---|
| Input Voltage(Vin)      |            | 9.0                    | 14.4 | 21.0                   | mArms |   |
| Open Circuit Voltage    |            | 1250                   | 1400 | 1700                   | Vrms  | IL =6.0 mArms   |
| Lamp Current            |            | 2.0<br>@SMB_DAT<br>FFH | -    | 6.0<br>@SMB_DAT<br>00H | mArms | Vin=14.4V   |
| Efficiency              | Optical    | -                      | 33.3 | -                      | Nit/W | After 30min turn on<br>at the center of LCD<br>Vin=14.4V @6.0mA |
|                         | Electrical | 75                     | 85   | -                      | %     |   |
| Operating Frequency     |            | 50±5                   | 55±5 | 60±5                   | kHz   | SMB_DAT=00H   |
| Input Voltage Ripple    |            | -                      | -    | 0.5                    | Vpp   | Peak to peak value  |
| Input Power Consumption |            | -                      | 4.5  | -                      | W     | (1)<br>Iout=6.0mArms  |
| In-rush current         |            | -                      | -    | 1                      | A     |   |
| Shutdown time           |            | 0.6                    | 1.0  | 1.4                    | sec   |   |
| Start-up time           |            | -                      | -    | 0.1                    | sec   | (2)   |

## Note

(1) Iin=312mA, Efficiency=85%

(2) Inverter start-up time

(3) Efficiency should be calculated as below formulation.

Optical efficiency = output Brightness(nits) / Input power(watt)

Electrical efficiency = output power / input power

(4) SEC recommends user to set the value of SMB\_Data to meet the minimum current(3.0mA) of Lamp.

.Reference value of SMB\_Data for 3.0mA of Lamp current : **COH***If the lamp current is under the 3.0mA, the lamp flicker may happen.*

## 4. BLOCK DIAGRAM

### 4.1 TFT LCD Module

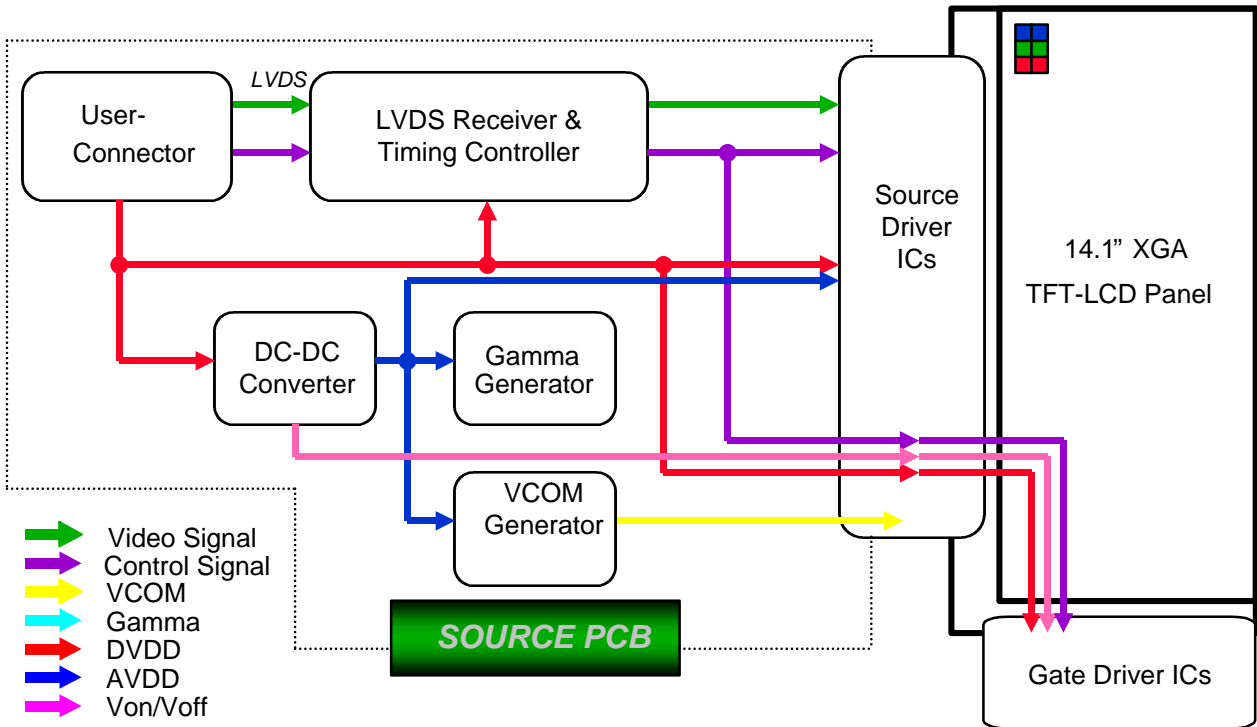

### 4.2 BACKLIGHT UNIT

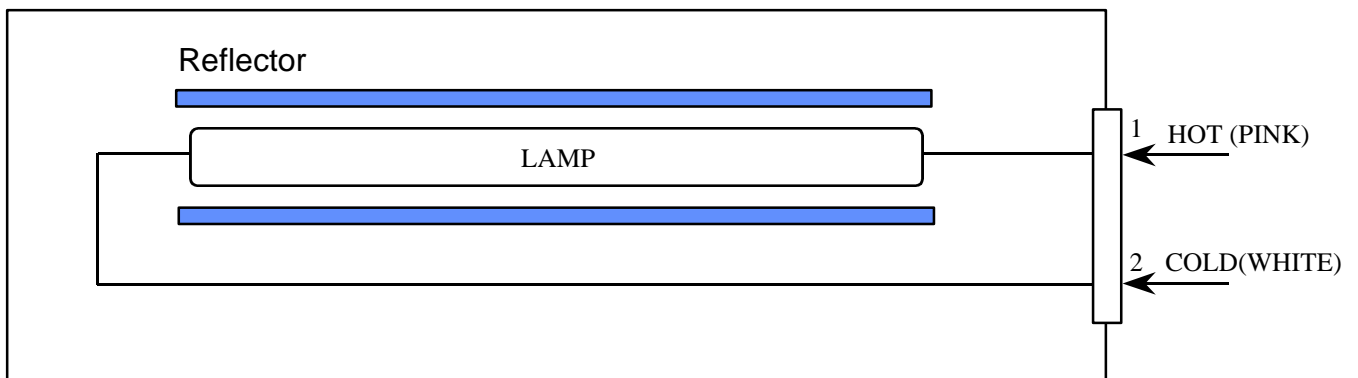

Note) The output of the inverter may change according to the material of the reflector.

### 4.3 INVERTER

Input Connector : JAE, WR-L16S-VF-1

Lamp Connector : JST, SM02B-BHSS-1-TB

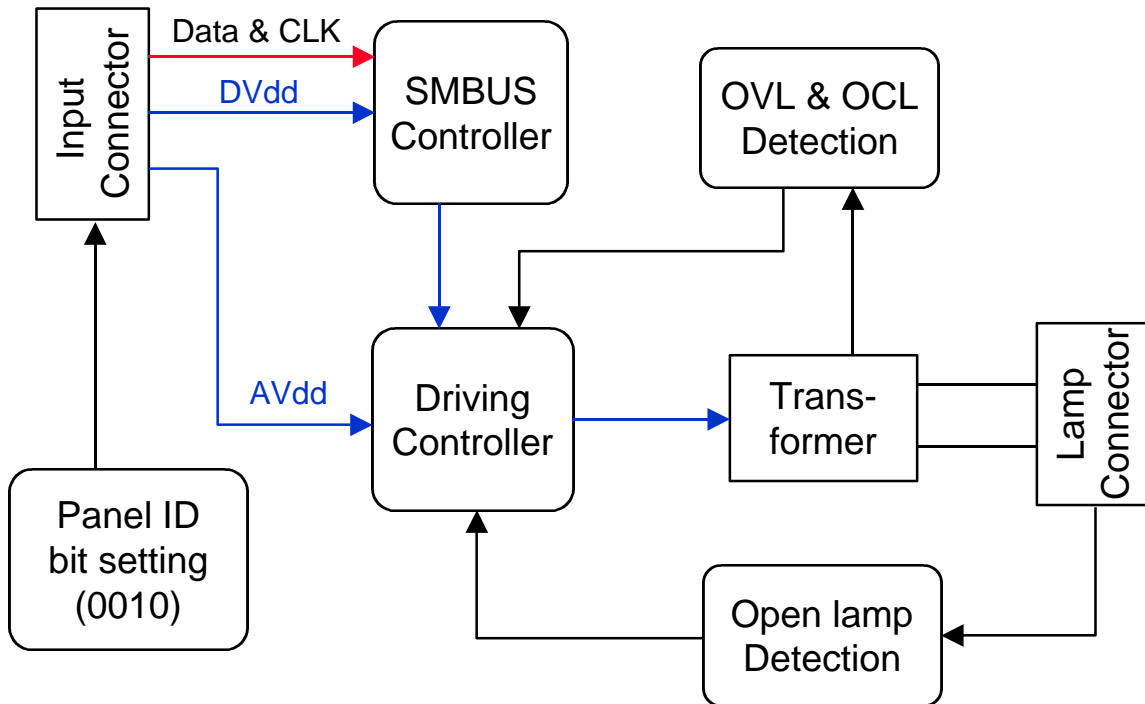

## 5. INPUT TERMINAL PIN ASSIGNMENT

5.1. Input Display Signal & Power (LVDS, Connector : FI-SEB-20P-HF10 or compatible  
Mating Connector : JAE FI-SE20M-HF)

| PIN NO | SYMBOL   | FUNCTION                     | POLARITY | REMARK                  |
|--------|----------|------------------------------|----------|-------------------------|
| 1      | VDD      | POWER SUPPLY +3.3V           |          |                         |
| 2      | VDD      | POWER SUPPLY +3.3V           |          |                         |
| 3      | GND      | GROUND                       |          |                         |
| 4      | GND      | GROUND                       |          |                         |
| 5      | RxIN0-   | LVDS Differential Data INPUT | Negative | R0~R5<br>G0             |
| 6      | RxIN0+   | LVDS Differential Data INPUT | Positive |                         |
| 7      | GND      | GROUND                       |          |                         |
| 8      | RxIN1-   | LVDS Differential Data INPUT | Negative | G1~G5<br>B0~B1          |
| 9      | RxIN1+   | LVDS Differential Data INPUT | Positive |                         |
| 10     | GND      | GROUND                       |          |                         |
| 11     | RxIN2-   | LVDS Differential Data INPUT | Negative | B2~B5,DE<br>Hsync,Vsync |
| 12     | RxIN2+   | LVDS Differential Data INPUT | Positive |                         |
| 13     | GND      | GROUND                       |          |                         |
| 14     | RxCLKIN- | LVDS Differential Data INPUT | Negative |                         |
| 15     | RxCLKIN+ | LVDS Differential Data INPUT | Positive |                         |
| 16     | GND      | GROUND                       |          |                         |
| 17     | NC       | No Connection                |          |                         |
| 18     | NC       | No Connection                |          |                         |
| 19     | GND      | GROUND                       |          |                         |
| 20     | GND      | GROUND                       |          |                         |



### 5.2 LVDS Interface : Transmitter SN75LVDS86 or Compatible

| Pin No. | Name   | RGB Signal | Pin No. | Name     | RGB Signal |
|---------|--------|------------|---------|----------|------------|
| 44      | TxIN0  | R0         | 12      | TxIN11   | G5         |
| 45      | TxIN1  | R1         | 13      | TxIN12   | B0         |
| 47      | TxIN2  | R2         | 15      | TxIN13   | B1         |
| 48      | TxIN3  | R3         | 16      | TxIN14   | B2         |
| 1       | TxIN4  | R4         | 18      | TxIN15   | B3         |
| 3       | TxIN5  | R5         | 19      | TxIN16   | B4         |
| 4       | TxIN6  | G0         | 20      | TxIN17   | B5         |
| 6       | TxIN7  | G1         | 22      | TxIN18   | Hsync      |
| 7       | TxIN8  | G2         | 23      | TxIN19   | Vsync      |
| 9       | TxIN9  | G3         | 25      | TxIN20   | DE         |
| 10      | TxIN10 | G4         | 26      | TxCLK IN | Clock      |

### LVDS INTERFACE

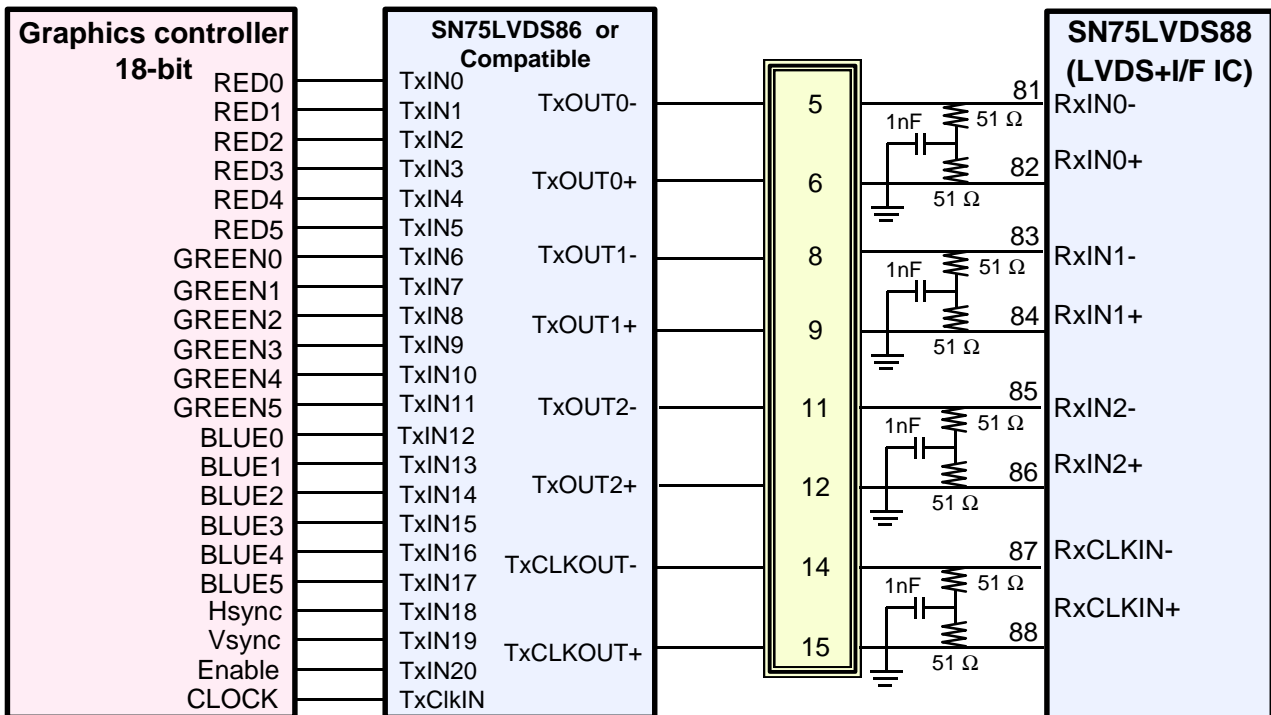

### 5.3 BACK LIGHT UNIT

Connector : JST BHSR - 02VS -1  
 Mating Connector : JST SM02B-BHSS-1

| Pin NO. | Symbol | Color | Function     |
|---------|--------|-------|--------------|
| 1       | HOT    | PINK  | High Voltage |
| 2       | COLD   | WHITE | Low Voltage  |

### 5.4 Timing Diagrams of LVDS For Transmission

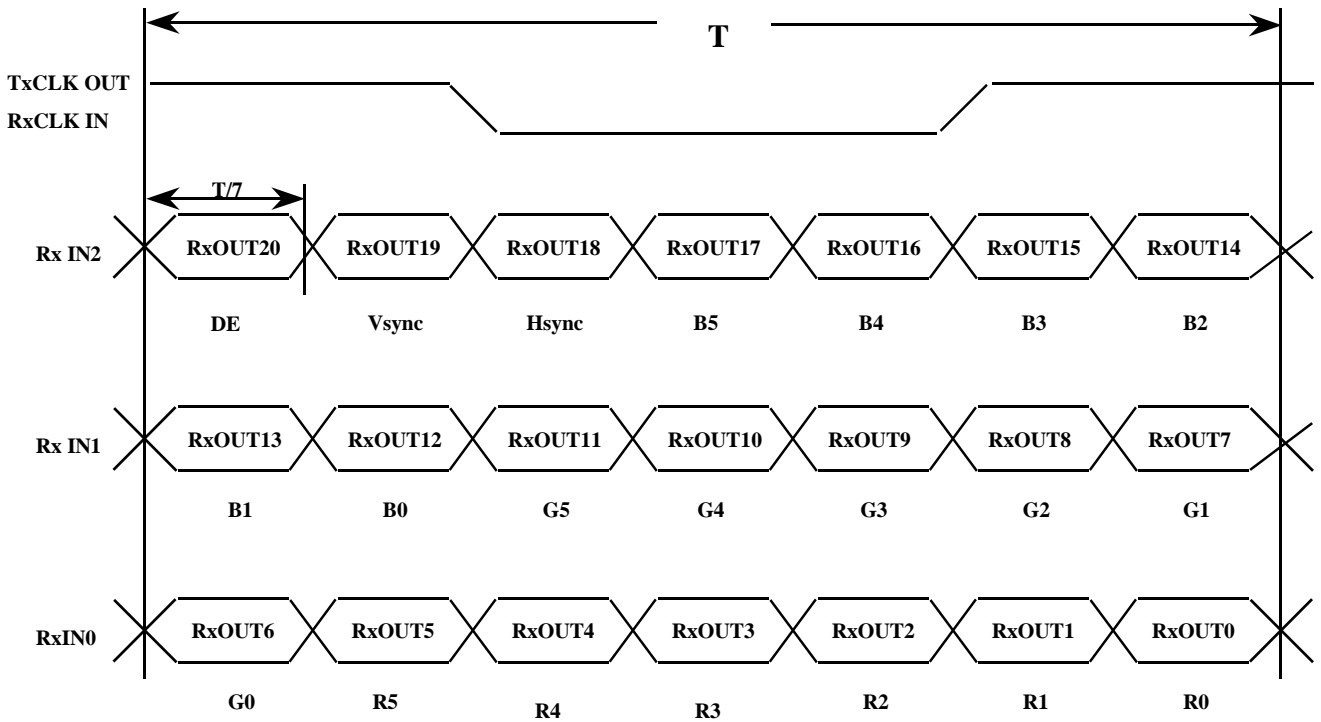

## 5.5 INVERTER signals &amp; power

Inverter Connector : JAE, WR-L16S-VF-1

| PIN NO | SYMBOL    | Voltage      | Comments   |
|--------|-----------|--------------|--|
| 1      | INV_SRC   | 9.0V to 21V  | This power rail should be used as a power rail to drive the back-light DC-AC converter.  |
| 2      | INV_SRC   | 9.0V to 21V  | This power rail should be used as a power rail to drive the back-light DC-AC converter.  |
| 3      | GND       | 0V           | Ground   |
| 4      | INV_SRC   | 9.0V to 21V  | This power rail should be used as a power rail to drive the back-light DC-AC converter.  |
| 5      | GND       | 0V           |  |
| 6      | GND       | 0V           |  |
| 7      | 5VSUS     | 4.85 to 5.2V | This should be used as power source for the control circuitry on the inverter.   |
| 8      | 5VALW     | 5V           | This should be used as power source that stores the brightness/contrast values & the circuit that interfaces with SMB_CLK & SMB_DAT. |
| 9      | SMB_DAT   | -            | SMBus interface for sending brightness & contrast information to the inverter/panel  |
| 10     | SMB_CLK   | -            | SMBus interface for sending brightness & contrast information to the inverter/panel  |
| 11     | FPVEE     | -            | Control signal input into the inverter to turn ON or OFF Lamp. (1 - ON, 0 - OFF)   |
| 12     | NC        | -            |  |
| 13     | PANEL_ID3 | -            | Output pin, See Note(2)  |
| 14     | PANEL_ID2 | -            | Output pin, See Note(2)  |
| 15     | PANEL_ID1 | -            | Output pin, See Note(2)  |
| 16     | PANEL_ID0 | -            | Output pin, See Note(2)  |

## Note (1) SMBus address Definition

SMBus address definition for brightness &amp; contrast

| Inverter SMBus address | A2 | A1 | A0 |
|------------------------|----|----|----|
| Address = 50h          | 0  | 0  | 0  |

✳ Recommend using Dallas Semiconductor DS1803-dual digital potentiometer (or equivalent). Use Wiper '0' for contrast control & Wiper '1' for brightness (backlight) control.

## Note (2) Panel ID bit Definition

| Panel type                               | Product ID   | ID3 | ID2 | ID1 | ID0 |
|--|--------------|-----|-----|-----|-----|
| 14.1" XGA single channel<br>LVDS TFT-LCD | LTN141X8-L02 | 0   | 0   | 1   | 0   |

## Note (3) Inverter Part Name

- Ambient : **K02I024.03**
  - \* K02I024.00 : Epoxy around the input connector
  - \* K02I024.03 : New connector (4 through hole type)
- Sumida : **PWB-IV11155T/B13**

## Note (4) Inverter revision number

- Ambient : **REV:9**
- Sumida : **REV:10**

### 5.6 Input Signal, Basic Display Colors and Gray Scale of Each Colors

| COLOR               | DISPLAY | DATA SIGNAL |    |    |    |    |       |    |    |    |    |      |    |    |    |    |    | GRAY SCALE LEVEL |        |
|---------------------|---------|-------------|----|----|----|----|-------|----|----|----|----|------|----|----|----|----|----|------------------|--------|
|                     |         | RED         |    |    |    |    | GREEN |    |    |    |    | BLUE |    |    |    |    |    |                  |        |
|                     |         | R0          | R1 | R2 | R3 | R4 | R5    | G0 | G1 | G2 | G3 | G4   | G5 | B0 | B1 | B2 | B3 |                  | B4     |
| BASIC COLOR         | BLACK   | 0           | 0  | 0  | 0  | 0  | 0     | 0  | 0  | 0  | 0  | 0    | 0  | 0  | 0  | 0  | 0  | 0                | -      |
|                     | BLUE    | 0           | 0  | 0  | 0  | 0  | 0     | 0  | 0  | 0  | 0  | 0    | 1  | 1  | 1  | 1  | 1  | 1                | -      |
|                     | GREEN   | 0           | 0  | 0  | 0  | 0  | 0     | 1  | 1  | 1  | 1  | 1    | 1  | 0  | 0  | 0  | 0  | 0                | -      |
|                     | CYAN    | 0           | 0  | 0  | 0  | 0  | 0     | 1  | 1  | 1  | 1  | 1    | 1  | 1  | 1  | 1  | 1  | 1                | -      |
|                     | RED     | 1           | 1  | 1  | 1  | 1  | 1     | 0  | 0  | 0  | 0  | 0    | 0  | 0  | 0  | 0  | 0  | 0                | -      |
|                     | MAGENTA | 1           | 1  | 1  | 1  | 1  | 1     | 0  | 0  | 0  | 0  | 0    | 0  | 1  | 1  | 1  | 1  | 1                | -      |
|                     | YELLOW  | 1           | 1  | 1  | 1  | 1  | 1     | 1  | 1  | 1  | 1  | 1    | 1  | 0  | 0  | 0  | 0  | 0                | -      |
|                     | WHITE   | 1           | 1  | 1  | 1  | 1  | 1     | 1  | 1  | 1  | 1  | 1    | 1  | 1  | 1  | 1  | 1  | 1                | -      |
| GRAY SCALE OF RED   | BLACK   | 0           | 0  | 0  | 0  | 0  | 0     | 0  | 0  | 0  | 0  | 0    | 0  | 0  | 0  | 0  | 0  | 0                | R0     |
|                     | DARK ↑  | 1           | 0  | 0  | 0  | 0  | 0     | 0  | 0  | 0  | 0  | 0    | 0  | 0  | 0  | 0  | 0  | 0                | R1     |
|                     |         | 0           | 1  | 0  | 0  | 0  | 0     | 0  | 0  | 0  | 0  | 0    | 0  | 0  | 0  | 0  | 0  | 0                | R2     |
|                     |         | :           | :  | :  | :  | :  | :     | :  | :  | :  | :  | :    | :  | :  | :  | :  | :  | :                | R3-R60 |
|                     | :       | :           | :  | :  | :  | :  | :     | :  | :  | :  | :  | :    | :  | :  | :  | :  | :  |                  |        |
|                     | ↓ LIGHT | 1           | 0  | 1  | 1  | 1  | 1     | 0  | 0  | 0  | 0  | 0    | 0  | 0  | 0  | 0  | 0  | 0                | R61    |
|                     |         | 0           | 1  | 1  | 1  | 1  | 1     | 0  | 0  | 0  | 0  | 0    | 0  | 0  | 0  | 0  | 0  | 0                | R62    |
|                     | RED     | 1           | 1  | 1  | 1  | 1  | 1     | 0  | 0  | 0  | 0  | 0    | 0  | 0  | 0  | 0  | 0  | 0                | R63    |
| GRAY SCALE OF GREEN | BLACK   | 0           | 0  | 0  | 0  | 0  | 0     | 0  | 0  | 0  | 0  | 0    | 0  | 0  | 0  | 0  | 0  | 0                | G0     |
|                     | DARK ↑  | 0           | 0  | 0  | 0  | 0  | 0     | 1  | 0  | 0  | 0  | 0    | 0  | 0  | 0  | 0  | 0  | 0                | G1     |
|                     |         | 0           | 0  | 0  | 0  | 0  | 0     | 0  | 1  | 0  | 0  | 0    | 0  | 0  | 0  | 0  | 0  | 0                | G2     |
|                     |         | :           | :  | :  | :  | :  | :     | :  | :  | :  | :  | :    | :  | :  | :  | :  | :  | :                | G3-G60 |
|                     | :       | :           | :  | :  | :  | :  | :     | :  | :  | :  | :  | :    | :  | :  | :  | :  | :  |                  |        |
|                     | ↓ LIGHT | 0           | 0  | 0  | 0  | 0  | 0     | 1  | 0  | 1  | 1  | 1    | 1  | 0  | 0  | 0  | 0  | 0                | G61    |
|                     |         | 0           | 0  | 0  | 0  | 0  | 0     | 0  | 1  | 1  | 1  | 1    | 1  | 0  | 0  | 0  | 0  | 0                | G62    |
|                     | GREEN   | 0           | 0  | 0  | 0  | 0  | 0     | 1  | 1  | 1  | 1  | 1    | 1  | 0  | 0  | 0  | 0  | 0                | G63    |
| GRAY SCALE OF BLUE  | BLACK   | 0           | 0  | 0  | 0  | 0  | 0     | 0  | 0  | 0  | 0  | 0    | 0  | 0  | 0  | 0  | 0  | 0                | B0     |
|                     | DARK ↑  | 0           | 0  | 0  | 0  | 0  | 0     | 0  | 0  | 0  | 0  | 0    | 0  | 1  | 0  | 0  | 0  | 0                | B1     |
|                     |         | 0           | 0  | 0  | 0  | 0  | 0     | 0  | 0  | 0  | 0  | 0    | 0  | 0  | 1  | 0  | 0  | 0                | B2     |
|                     |         | :           | :  | :  | :  | :  | :     | :  | :  | :  | :  | :    | :  | :  | :  | :  | :  | :                | B3-B60 |
|                     | :       | :           | :  | :  | :  | :  | :     | :  | :  | :  | :  | :    | :  | :  | :  | :  | :  |                  |        |
|                     | ↓ LIGHT | 0           | 0  | 0  | 0  | 0  | 0     | 0  | 0  | 0  | 0  | 0    | 0  | 1  | 0  | 1  | 1  | 1                | B61    |
|                     |         | 0           | 0  | 0  | 0  | 0  | 0     | 0  | 0  | 0  | 0  | 0    | 0  | 0  | 1  | 1  | 1  | 1                | B62    |
|                     | BLUE    | 0           | 0  | 0  | 0  | 0  | 0     | 0  | 0  | 0  | 0  | 0    | 0  | 1  | 1  | 1  | 1  | 1                | B63    |

**Note**

- (1) Definition of Gray : Rn : Red Gray, Gn : Green Gray, Bn : Blue Gray (n = Gray level)
- (2) Input Signal : 0 = Low level voltage, 1 = High level voltage

# 5.7 PIXEL FORMAT

APPROVAL

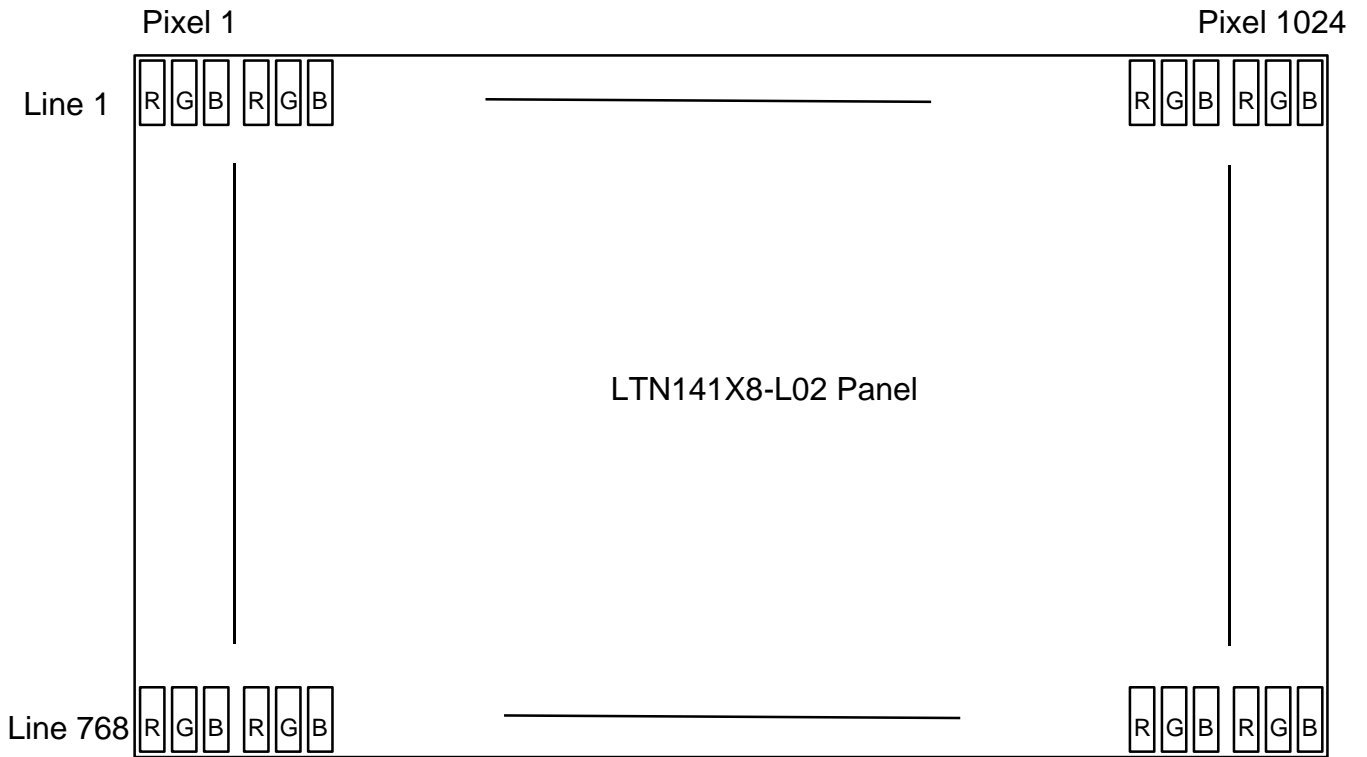

## 6. INTERFACE TIMING

### 6.1 Timing Parameters

| Signal                         | Item           | Symbol   | MIN | TYP  | MAX | Unit   | Note |
|--------------------------------|----------------|----------|-----|------|-----|--------|------|
| Frame Frequency                | Cycle          | $T_v$    |     | 806  |     | lines  |      |
| Vertical Active Display Term   | Display Period | $T_{vD}$ |     | 768  |     | lines  |      |
| One Line Scanning Time         | Cycle          | $T_H$    |     | 1344 |     | clocks |      |
| Horizontal Active Display Term | Display Period | $T_{HD}$ |     | 1024 |     | clocks |      |

### 6.2 Timing diagrams of interface signal

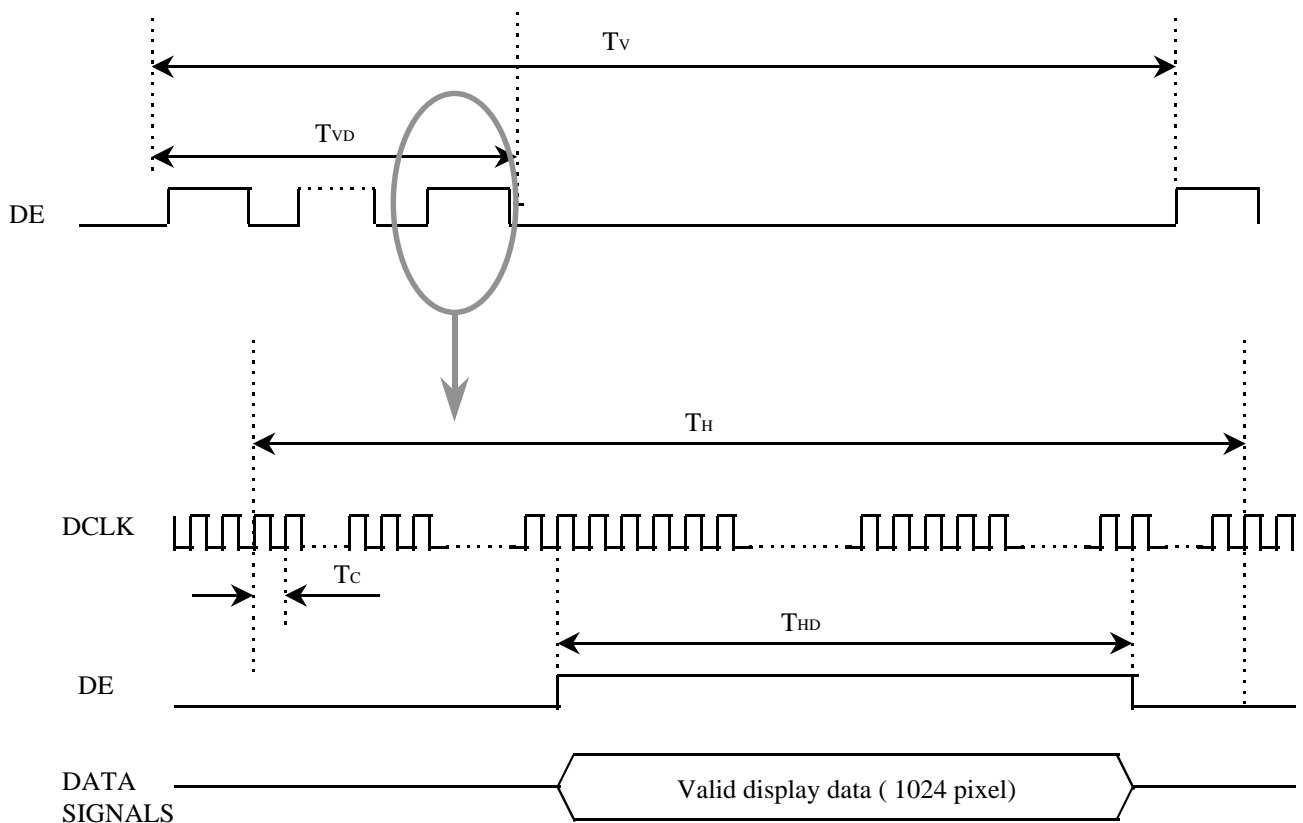

### 6.3 Power ON/OFF Sequence

: To prevent a latch-up or DC operation of the LCD module, the power on/off sequence shall be as shown below.

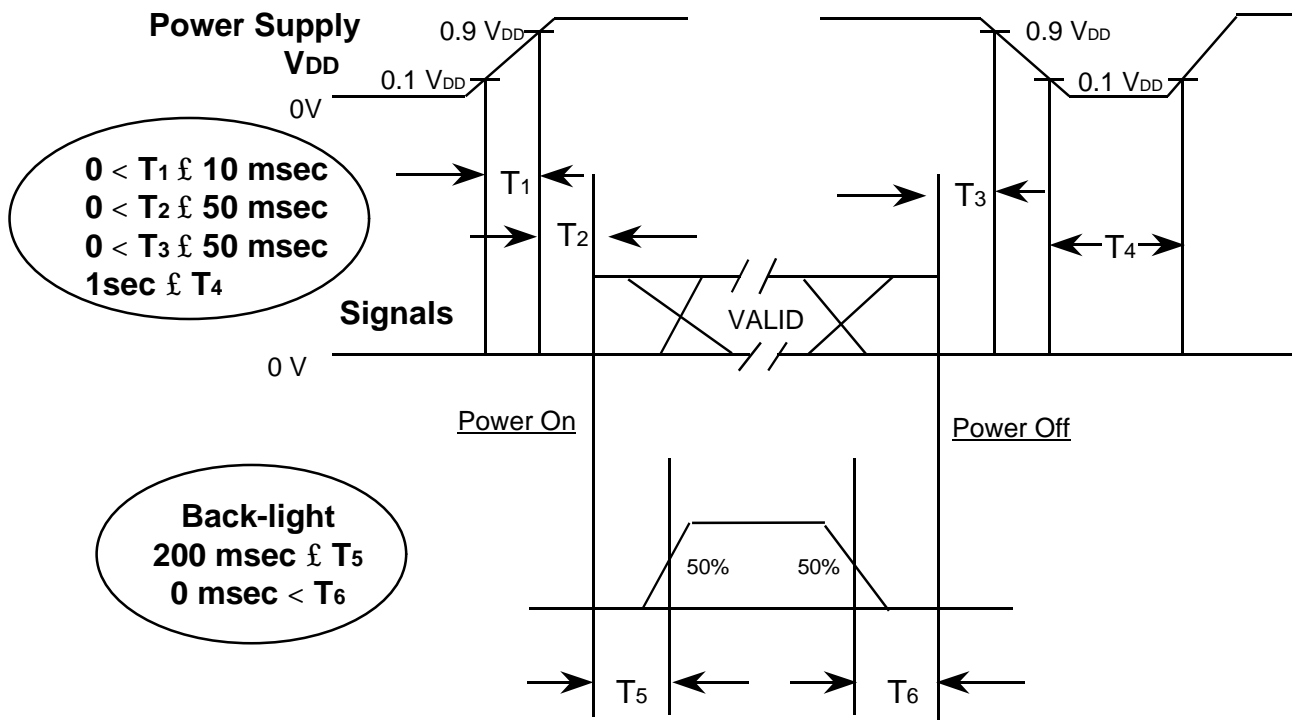

Power ON/OFF Sequence

- T1 : Vdd rising time from 10% to 90%
- T2 : The time from Vdd to valid data at power ON.
- T3 : The time from valid data off to Vdd off at power Off.
- T4 : Vdd off time for Windows restart
- T5 : The time from valid data to B/L enable at power ON.
- T6 : The time from valid data off to B/L disable at power Off.

**NOTE.**

- (1) The supply voltage of the external system for the module input should be the same as the definition of V<sub>DD</sub>.
- (2) Apply the lamp voltage within the LCD operation range. When the backlight turns on before the LCD operation or the LCD turns off before the backlight turns off, the display may momentarily become white.
- (3) In case of V<sub>DD</sub> = off level, please keep the level of input signals on the low or keep a high impedance.
- (4) T<sub>4</sub> should be measured after the module has been fully discharged between power off and on period.
- (5) Interface signal shall not be kept at high impedance when the power is on.



| NO | PART NAME | CODE NO | SPECIFICATION | Q'TY | WEIGHT<br>FINISH MATERIAL | INFLUENCED DIM.<br>OF MATERIAL | REMARK |
|----|-----------|---------|---------------|------|---------------------------|--------------------------------|--------|
|----|-----------|---------|---------------|------|---------------------------|--------------------------------|--------|

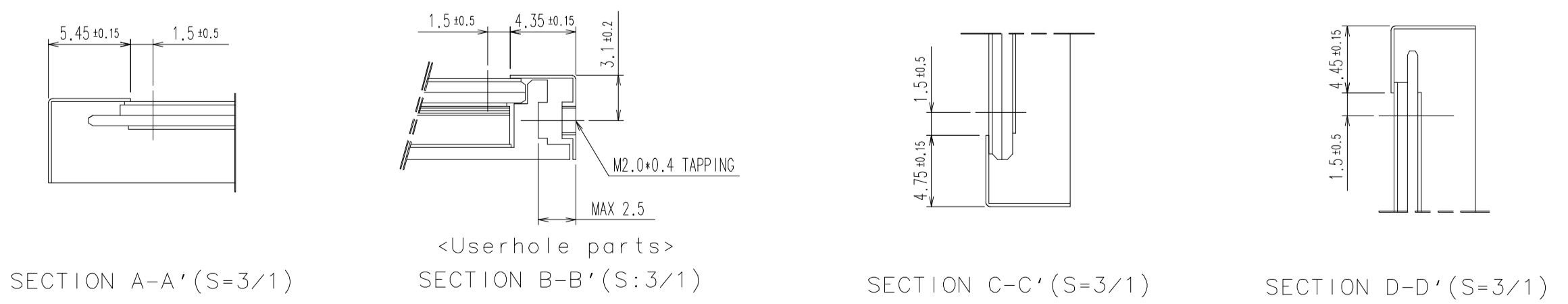
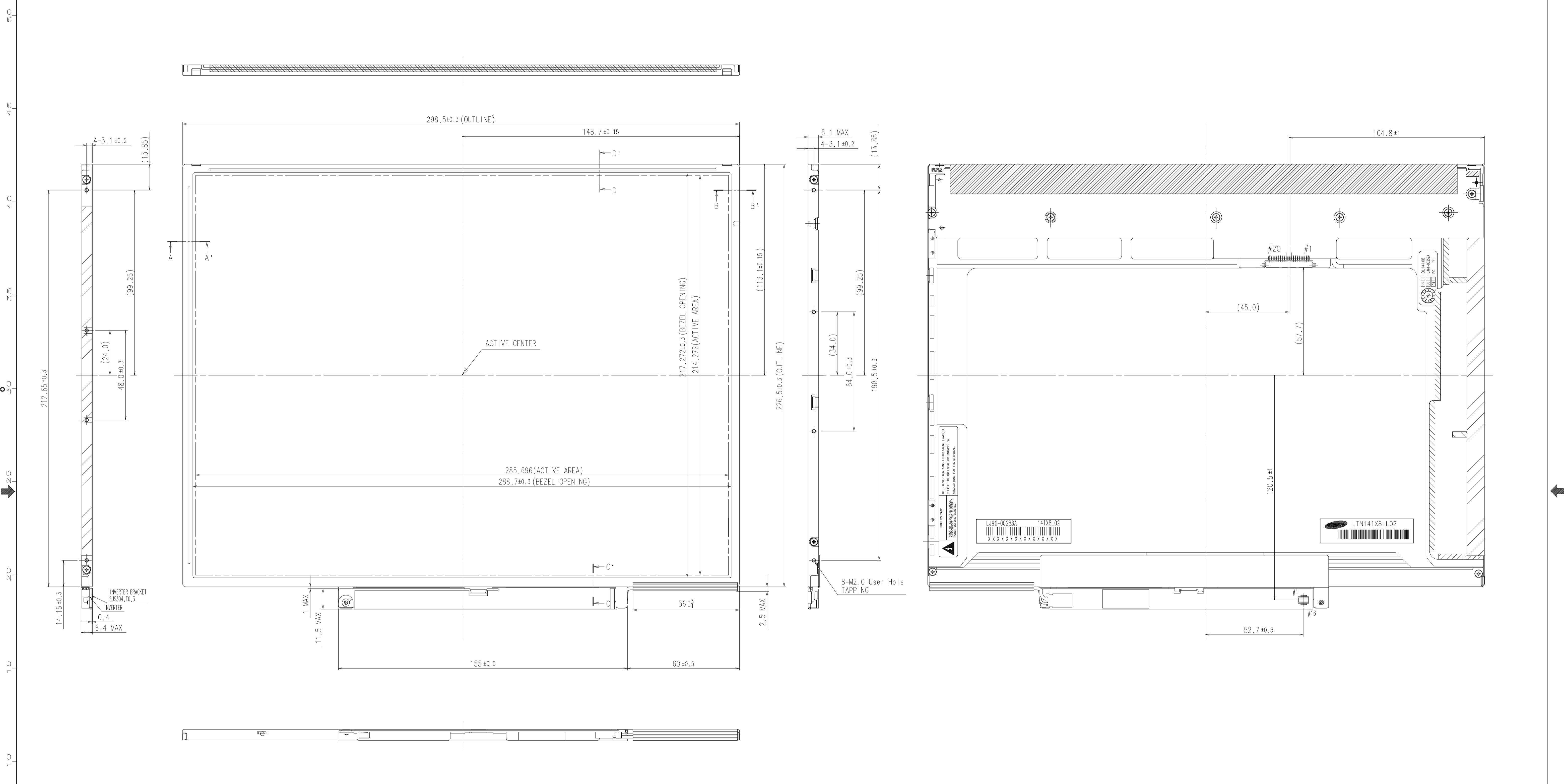

- \* NOTE
- SIGNAL INTERFACE CONNECTOR TO BE SPECIFIED AS BELOW.
    - MAKER : UJU
    - PART NO : 1524B-2041R
    - INPUT MATCHING CONNECTOR : JAE F1-SE20M-HF
  - CCFT CONNECTOR FOR BACKLIGHT TO BE SPECIFIED AS BELOW.
    - MAKER : JST
    - PART NO : BHSR-02VS-1
    - LAMP DIAMETER :  $\phi 2.0$

REVISION

| GENERAL TOLERANCE |         |         |         | REV       | DATE | DESCRIPTION OF REVISION |          |          | REASON   | CHG'D BY          |
|-------------------|---------|---------|---------|-----------|------|-------------------------|----------|----------|----------|-------------------|
| STEP              | LEVEL 1 | LEVEL 2 | LEVEL 3 | UNIT      | mm   | DRA'N BY                | DES'D BY | CHK'D BY | APP'D BY | MODEL NAME        |
| 0 < X ≤ 4         | ±0.05   | ±0.1    | ±0.2    | SCALE     | 1/1  | J.C. CHO1               | S.H. LEE | Y.B. CHU |          | LTN141X8-L02      |
| 4 < X ≤ 16        | ±0.08   | ±0.15   | ±0.3    | TOLERANCE |      | 00.6.2                  | 00.6.2   | 00.6.2   |          | OUTLINE DIMENSION |
| 16 < X ≤ 64       | ±0.12   | ±0.25   | ±0.5    | LEVEL 3   |      |                         |          |          |          | SHEET 1/1         |
| 64 < X ≤ 256      | ±0.25   | ±0.4    | ±0.8    |           |      |                         |          |          |          | VER. 00           |

SAMSUNG ELECTRONICS

**8. PACKING**

1. CARTON(Internal Package)

(1) Packing Form

Corrugated Cardboard box and Corrupad form as shock absorber

(2) Packing Method

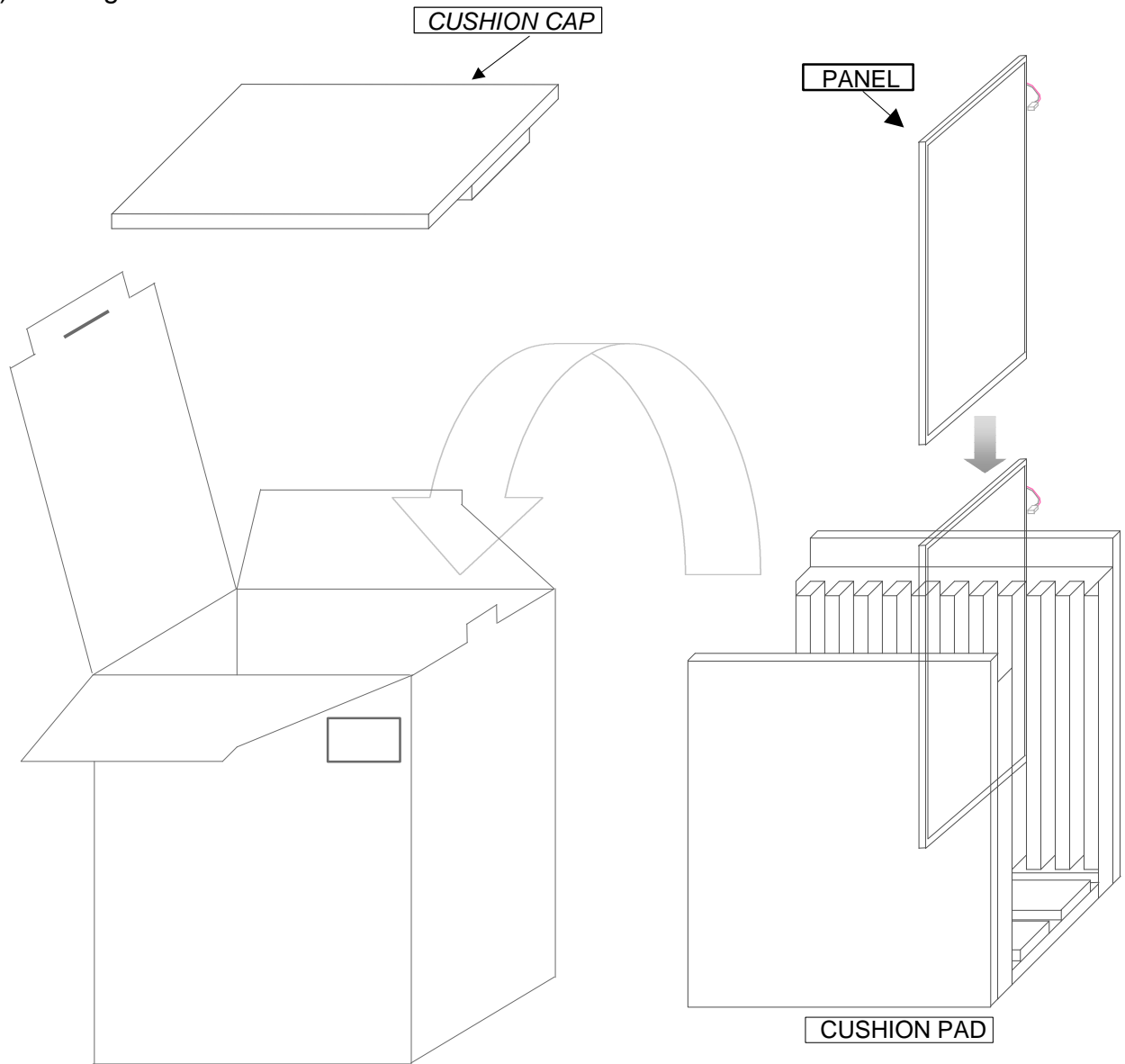

- Note 1) Total Weight : Approximately 6.0 kg
- 2) Acceptance number of piling : 10 sets
- 3) Carton size : 317(W)×286(D)×355(H)
- 4) MAX accumulation quantity : 5 cartons

PACKING CASE

| No | Part name  | Quantity |
|----|--|----------|
| 1  | Static electric protective sack                    | 10       |
| 2  | Packing case(Inner box)<br>included shock absorber | 1 set    |
| 3  | Pictorial marking                                  | 2 pics   |
| 4  | Carton   | 1 set    |

**9. MARKINGS & OTHERS**

A nameplate bearing followed by is affixed to a shipped product at the specified location on each product.

- (1)Parts number : LTN141X8-L02
- (2)Revision : One letter
- (3)Control code : One letter
- (4)Lot number : 3 M O K XXXXXX XXX

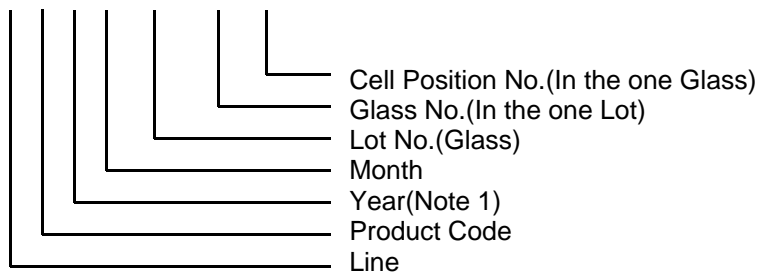

NOTE 1). This code indicating year is omitted in the products of Chun-an site.

(5) Nameplate Indication (Dell PPID Label)

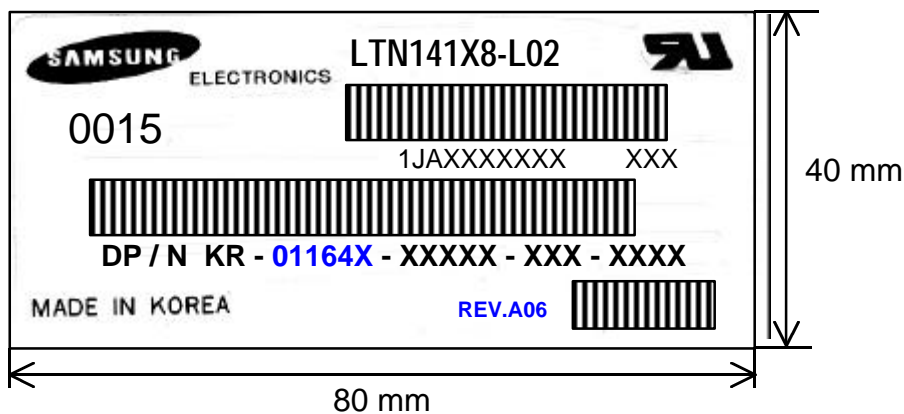

Parts name : LTN141X8 - L02  
 Lot number : 3MOKXXXXXX XXX  
 Inspected work week : 0015  
 DP/N : Dell Part Number ("01164X" is for 141X8-L02)  
 REV.A06 : Product Revision Code

High voltage caution label

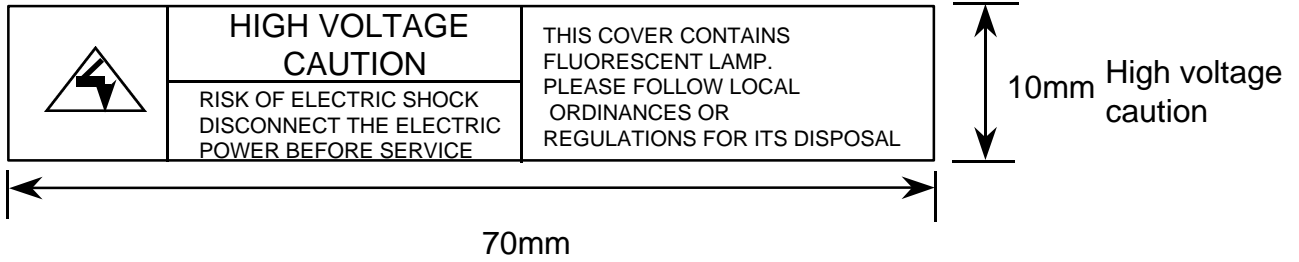

(6) Packing box attach

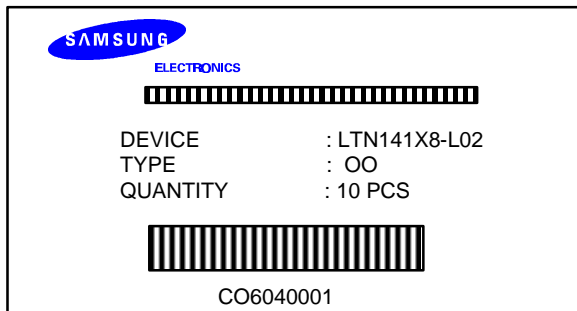

(7) Packing box Marking : Samsung TFT-LCD Brand Name



## 10. GENERAL PRECAUTIONS

APPROVAL

### 1. Handling

- (a) When the module is assembled, It should be attached to the system firmly using every mounting holes. Be careful not to twist and bend the modules.
- (b) Refrain from strong mechanical shock and / or any force to the module. In addition to damage, this may cause improper operation or damage to the module and CCFT back-light.
- (c) Note that polarizers are very fragile and could be easily damaged. Do not press or scratch the surface harder than a HB pencil lead.
- (d) Wipe off water droplets or oil immediately. If you leave the droplets for a long time, Staining and discoloration may occur.
- (e) If the surface of the polarizer is dirty, clean it using some absorbent cotton or soft cloth.
- (f) The desirable cleaners are water, IPA(Isopropyl Alcohol) or Hexane. Do not use Ketone type materials(ex. Acetone), Ethyl alcohol, Toluene, Ethyl acid or Methyl chloride. It might permanent damage to the polarizer due to chemical reaction.
- (g) If the liquid crystal material leaks from the panel, it should be kept away from the eyes or mouth. In case of contact with hands, legs or clothes, it must be washed away thoroughly with soap.
- (h) Protect the module from static, it may cause damage to the C-MOS Gate Array IC.
- (i) Use fingerstalls with soft gloves in order to keep display clean during the incoming inspection and assembly process.
- (j) Do not disassemble the module.
- (k) Do not pull or fold the lamp wire.
- (l) Do not adjust the variable resistor which is located on the back side.
- (m) Protection film for polarizer on the module shall be slowly peeled off just before use so that the electrostatic charge can be minimized.
- (n) Pins of I/F connector shall not be touched directly with bare hands.

## 2. STORAGE

- (a) Do not leave the module in high temperature, and high humidity for a long time.  
It is highly recommended to store the module with temperature from 0 to 35 °C and relative humidity of less than 70%.
- (b) Do not store the TFT-LCD module in direct sunlight.
- (c) The module shall be stored in a dark place. It is prohibited to apply sunlight or fluorescent light during the store.

## 3. OPERATION

- (a) Do not connect, disconnect the module in the “ Power On” condition.
- (b) Power supply should always be turned on/off by following item 6.3 “ Power on/off sequence “.
- (c) Module has high frequency circuits. Sufficient suppression to the electromagnetic interference shall be done by system manufacturers. Grounding and shielding methods may be important to minimize the interference.
- (d) The cable between the back-light connector and its inverter power supply shall be a minimized length and be connected directly . The longer cable between the back-light and the inverter may cause lower luminance of lamp(CCFT) and may require higher startup voltage(Vs).

## 4. OTHERS

- (a) Ultra-violet ray filter is necessary for outdoor operation.
- (b) Avoid condensation of water. It may result in improper operation or disconnection of electrode.
- (c) Do not exceed the absolute maximum rating value. ( the supply voltage variation, input voltage variation, variation in part contents and environmental temperature, so on)  
Otherwise the module may be damaged.
- (d) If the module displays the same pattern continuously for a long period of time, it can be the situation when the image “ sticks” to the screen.
- (e) This module has its circuitry PCB' s on the rear side and should be handled carefully in order not to be stressed.